

Agilent E1415A, E1422A Algorithmic Closed Loop Controller and Remote Channel Multifunction Data Acquisition & Control Module

Data Sheet

- Powerful data acquisition capability
- Powerful control capability
- Comprehensive on-board signal conditioning
- Custom on-board DSP program development
- Wide choice of input/output signal types
- Large channel-count strain signal conditioning and measurement

Description

The Agilent Technologies E1415A and E1422A are **C-size, 1-slot, VXI modules** capable of either multi-function input/output (data acquisition) or powerful control capabilities. They serve as powerful data acquisition modules that handle analog input/output and digital input/output in both static and dynamic modes. The digital capability includes the ability to set or sense static states, to measure input frequency and period, to totalize, and to input or output PWM and FM signals.

Refer to the Agilent Technologies Website for instrument driver availability and downloading instructions, as well as for recent product updates, if applicable.

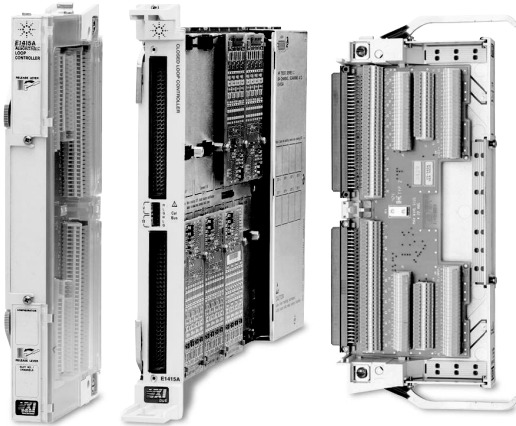

Agilent E1415A



Algorithmic Closed Loop Controller Agilent E1415A

More powerful than PID controllers and easier to implement than large custom control systems, the E1415A fills a unique niche in the data acquisition and control field, providing both control and precise data acquisition. Applications include:

- PID control of stimulus loops such as hydraulic actuators, levers, rotational devices as in structural test
- PID control of temperature, position, velocity, acceleration etc.
- Complex control such as cascade loops in thermal cooling jackets, ratio
- Independent loops with multi-level alarms.

The design of the on-board, DSP firmware assures the user that all inputs, all calculations, and all outputs can be completed between scan triggers. This means there is no drift, or jitter in the critical time intervals that are used to calculate integrals and derivatives in control algorithms.

The firmware allows a user to employ pre-written Agilent PID control algorithms, modify them for specific application needs, or to write an application from scratch. Low duty-cycle connection to the host computer allows interaction between the host and real-time DSP so the user can update algorithms, change tuning constants, or do envelope control. Limited host computer interaction leads to very high performance (8-loops, update rate 1000/second per loop with simple PID calculation included).

Remote Channel Multi-Function Data Acquisition & Control Module Agilent E1422A

The E1422A is a module that is essentially the same as the E1415A and has all of the same data acquisition and control capabilities as the E1415A, and then some. The few minor differences are described here.

The E1422A Remote Channel Multi-Function DAC Module supports the E1539A Remote Channel Signal Conditioning Plug-on, and the E1529A Remote Strain Signal Conditioning Unit to form a high-performance but economical Strain Measurement System. The E1422A serves as the controller in this system, managing all the configuration, calibration, triggering of measurements, EU conversion and calibration processes.

The principal differences between the E1415A and E1422A are these:

- The E1422A has 40 Kbytes of memory available for user algorithms; the E1415A has 48 Kbytes.
- If the only thing being done in an application is collection of strain data, the E1422A user doesn't have to write an algorithm, as for the E1415A.
- The E1422A offers the same two Terminal Blocks (Option 011 screw terminals and Option 013 spring clamp) as does the E1415A. Additionally, the E1422A offers a third Terminal Block (Option 001 16 RJ-45 connectors). Option 001 is very powerful for a system dedicated solely to strain measurements, but doesn't have an isothermal strip (as Options 011 and 013 do), and should not be used with thermocouples. Options 011 and 013 can be used for general-purpose data acquisition, including thermocouples. For strain, the 4-pair cable connections are wired directly into the terminal block.

Automated Calibration for Better Measurements

The E1415A and E1422A offer superior calibration capabilities that provide more accurate measurements. Periodic calibration of the module's measurement inputs is accomplished by connecting an external voltage measurement standard (such as a highly accurate multimeter) to the inputs of the module. This external standard first calibrates the on-board calibration source. Then built-in calibration routines use the on-board calibration source and on-board switching to calibrate the entire signal path from the closed loop controller's input, through the signal conditioning plug-ons (SCPs) and FET MUX, to the A/D itself. Subsequent daily or short-term calibrations of this same signal path can be quickly and automatically done using the internal calibration source to eliminate errors introduced by the signal path through the SCPs and FET MUX or by ambient temperature changes. All input channels can be quickly and productively calibrated to assure continued high-accuracy measurements.

In addition to the calibration of the signal paths within the modules, the E1415A and E1422A allow you to perform a "Tare Cal" to reduce the effects of voltage offsets and IR voltage drops in your signal wiring that is external to the module. The Tare Cal uses an on-board D/A to eliminate these voltage offsets. By placing a short circuit across the signal or transducer being measured, the residual offset can be automatically measured and eliminated by the D/A. Tare Cal should not be used to eliminate the thermoelectric voltage of thermocouple wire on thermocouple channels.

Flexibility with Deterministic Control

The E1415A and E1422A are digital sampling closed loop control systems that are complete in a single VXI module. All signal conditioning, process monitoring, control calculations, and control signals are handled on-board without the need for computer supervision. Once setup is done, the module is essentially free-running.

The inputs are updated at the beginning of each cycle and the outputs are updated at a later deterministic time in the cycle so that various paths in the control algorithm do not affect the loop timing. These steps are executed automatically and deterministically without need for intervention from a system computer.

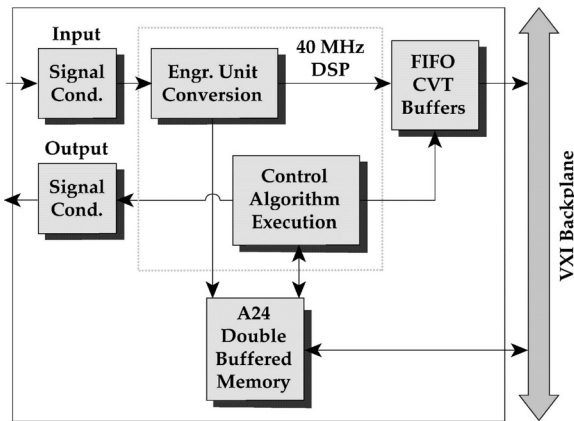

Digital Sampling Closed Loop Control System

The E1415A/E1422A combine flexibility with deterministic control. Control algorithms for each of the loops can be the default PID calculation or a user-defined, downloaded, custom algorithm. The loop update rate is deterministically controlled by an internal clock so that variations in the algorithm execution times do not affect the loop cycle time.

There are four steps to each control cycle: 1) Input channels are measured, 2) System inputs are updated, 3) Control algorithms are executed, and 4) Output signals are updated.

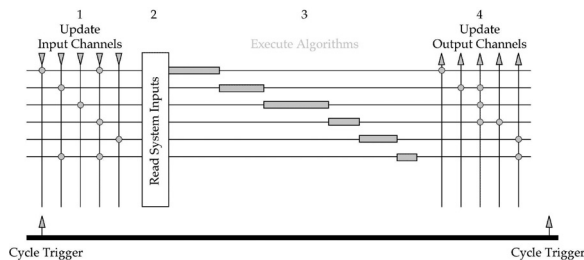

Four Steps to Control Cycle

Powerful Control Capability

The control algorithm for each loop is easily developed by the user from a list of algebraic expressions and flow constructs such as IF, THEN, ELSE. Tuning is simplified because all of the constants in the algorithm as well as the algorithm itself can be updated on-the-fly. New values are double-buffered so there is no need to stop scanning the inputs or halt the algorithm execution.

The on-board 40 MHz pipelined DSP provides highly deterministic execution, making it easy to accurately predict cycle times. Engineering unit conversions for temperature, strain, resistance, and voltage measurements are made automatically without slowing down the algorithm execution speed.

Wide Choice of Inputs/Outputs

The inputs to the loop algorithm can be measured values from multiple channels, operator input values, outputs from other loops, or values from other subsystems. The E1415A/E1422A have a variety of signal conditioning plug-ins for making measurements of:

- Temperature, strain
- Voltage, current, resistance
- RPM, frequency, totalize
- Discrete levels, TTL, contact closures

In addition, the measured input values and the calculated output values can be stored in a 64,000-sample FIFO buffer and efficiently transferred to the controlling computer in blocks of data. With this feature, it is no longer necessary to waste resources by dedicating a data acquisition channel to monitor each control loop input and output. The result of any algorithm calculation can be an input for use by another loop or subsystem, or it can be a direct output of several different types. Among the choices of output are:

- Analog voltage
- Analog current
- Discrete levels (TTL)
- Pulse width modulation (TTL)

As an example of output flexibility, the pulse width modulation output has several modes. In the PWM free-run mode, the frequency or pulse width output rate is independent of the loop update rate and can be changed once per loop update cycle. The square wave mode provides a variable frequency, fixed 50% duty cycle output signal. The pulse-per-update mode provides a variable width pulse synchronized to the loop update cycle.

Operator Control

Manual control can be implemented through a user software interface or external hardware, such as a potentiometer. Bumpless transfer from auto to manual mode, or manual to auto is handled automatically by a set-point-tracking routine in the default PID algorithm code.

Signal Conditioning Plug-Ons

A Signal Conditioning Plug-on (SCP) is a small daughter board that mounts on Agilent's VXI scanning measurement and control modules. These SCPs provide a number of input and output functions. Several include gain and filtered analog inputs for measuring electrical and sensor-based signals, as well as frequency, total event count, pulse-width modulation, toothed-wheel velocity, and digital state. Output functions include analog voltage and current D/As, 8- or 16-bit digital outputs, pulse output with variable frequency and PWM, and stepper motor control.

Refer to the information on each individual SCP for more details.

Voltage Measurements

Use any of the following SCPs with the E1415A/E1422A to make voltage measurements: E1501A, E1502A, E1503A, E1508A, E1509A, E1512A or E1513A.

Temperature Measurements

Any of the input SCPs can be used to make temperature measurements with thermocouples, thermistors, or RTDs, but the E1503A/E1508A/E1509A SCPs provide higher accuracy with thermocouples.

Resistance Measurements

Resistance is measured using either the E1505A 8-Channel Current Source SCP and an input SCP or the E1518A 4-Wire Resistance Measurement SCP. Measurements are made by applying a dc current to the unknown and measuring the voltage drop across the unknown.

Static Strain Measurements

There are two ways to make static strain measurements. The E1506A and E1507A SCPs provide a convenient way to measure a few channels of static strain. When using the E1506A/E1507A for bridge completion, a second SCP is required to make the measurement connection. You can use the following SCPs for this type of static strain measurements:

- E1503A 8-Channel Programmable Filter/Gain SCP
- E1506A 8-Channel 120 Ω Strain Completion & Excitation SCP
- E1507A 8-Channel 350 Ω Strain Completion & Excitation SCP
- E1508A 8-Channel 7 Hz Fixed Filter & x16 Gain SCP
- E1509A 8-Channel 7 Hz Fixed Filter & x64 Gain SCP

The combination of the E1422A/E1529A/E1539A provide a more cost-effective approach to static (and dynamic) strain measurements, especially for applications requiring more than eight channels. Dynamic strain measurements are implemented by connecting the E1529A to high-speed digitizers, such as the Agilent E1432A and E1433B.

Note: SCPs are also available for making dynamic strain measurements (Agilent E1510A and E1511A).

Transient Measurements

When making higher speed measurements, a vital issue often is the time skew between channels. Ideally, in many applications, the sampled data is needed at essentially the same instant in time. While the intrinsic design of the E1415A/E1422A provides scanning of 64 channels, with maximum skew of 640 μ S between the first and last channel (far less than most sampled data systems), this still may not be small enough skew for some applications.

Transient Voltage Measurements

The E1510A provides basic sample-and-hold capabilities on four channels. Six-pole Bessel filters provide alias and alias-based noise reduction while giving excellent transient response without overshoot or ringing. The E1510A can be used in strain applications primarily where the bridge is external.

Transient Strain Measurements

The E1511A, a double-wide SCP, has all the capabilities of the E1510A but adds on-board bridge excitation and completion functions. The four direct input channels are used for monitoring the bridge excitation. A maximum of four SCPs (16 channels) can be installed on an E1415A/E1422A.

Analog Output

Use the E1531A for voltage outputs, and the E1532A for current outputs. The E1531A and E1532A have eight (8) output channels available on each SCP.

A maximum of seven (7) E1532A SCPs can be installed on each E1415A/E1422A due to power limitations. There are no power restrictions on the E1531A.

Digital I/O

Use the E1533A Digital I/O SCP to provide two 8-bit input/output words.

Frequency/Totalize/PWM

The E1538A Enhanced Frequency/Totalize/PWM SCP provides eight (8) channels which can be individually configured as a frequency or totalizer input, or as a pulse width modulated output.

Compact Packaging with Signal Conditioning

The E1415A/E1422A provide for configurable signal conditioned I/O with up to eight individual plug-ons for analog, digital, and frequency needs. The capabilities of the SCPs for the E1415A/E1422A are:

- E1501A 8-Channel Direct Input SCP
- E1502A 8-Channel 7 Hz Low-pass Filter SCP
- E1503A 8-Channel Programmable Filter and Gain SCP
- E1505A 8-Channel Current Source SCP
- E1506A 8-Channel 120 Ω Strain Completion & Excitation SCP
- E1507A 8-Channel 350 Ω Strain Completion & Excitation SCP
- E1508A 8-Channel x16 Gain & 7 Hz Fixed Filter SCP
- E1509A 8-Channel x64 Gain & 7 Hz Fixed Filter SCP
- E1510A 4-Channel Sample & Hold Input SCP
- E1511A 4-Channel Transient Strain SCP
- E1512A 8-Channel 25 Hz Fixed Filter SCP
- E1513A 8-Channel Divide-by-16 Fixed Attenuator & 7 Hz Low-pass Filter SCP
- E1518A 4-Wire Resistance Measurement SCP
- E1531A 8-Channel Voltage Output SCP
- E1532A 8-Channel Current Output SCP
- E1533A 16-Bit Digital I/O SCP
- E1536A 8-Bit Isolated Digital I/O SCP
- E1538A Enhanced Frequency/Totalize/PWM SCP
- E1539A Remote Channel SCP (E1422A only)

Product Specifications

Note: For specifications of the E1422A used with the E1529A/E1539A as a remote strain measurement system, see the E1529A/E1539A section. For other functions of the E1422A, refer to the following E1415A/E1422A specifications.

Timing Signals

Timing:	Scan-to-scan timing and sample-to-sample timing can be set independently.
Scan triggers:	Can be derived from a software command or a TTL level from other VXI modules, internal timer, or external hardware. Typical latency 17.5 μ s.
Synchronization:	Multiple E1415A/E1422A modules can be synchronized at the same rate using the TTL trigger output from one E1415A/E1422A to trigger the others.
Alternate synchronization:	Multiple E1415A/E1422A modules can be synchronized at different integer-related rates using the ALG:SCAN:RATIO command and the TTL trigger output from one E1415A/E1422A module to trigger the others.

Scan Triggers

Internal:	100 μ sec to 6.5536 sec
Resolution:	100 μ sec
Trigger count:	1 to 65535 or infinite

Sample Timer

Range:	E1415A: 10 μ sec to 32768 msec E1422A: 40 μ sec to 32768 msec
Resolution:	0.5 μ sec

Measurement Specifications

The following specifications include the SCP and scanning A/D performance together as a unit. Accuracy is stated for a single sample. Averaging multiple samples will improve accuracy by reducing noise of the signal. The basic E1415A/E1422A scanning A/D has a full scale range of ± 16 V and five autoranging gains of x1, x4, x16, x64, and x256. An SCP must be used with each eight-channel input block to provide input protection and signal conditioning. Refer to the information on each individual SCP for measurement specifications.

Note: For field wiring, the use of shielded twisted pair wiring is highly recommended.

Measurement resolution:	16 bits (including sign)
Maximum reading rate:	E1415A: Up to 56 kSamples/s dependent upon configuration E1422A: Up to 25 kSamples/s dependent upon configuration
Memory:	64 kSa
Maximum input voltage:	Normal mode plus common mode
Operating:	<± 16 V peak
Damage level:	>± 42 V peak
Maximum common mode voltage:	
Operating:	<± 16 V peak
Damage level:	>± 42 V peak
SCP input impedance:	>100 MΩ differential
Maximum tare cal offset:	62.5 mV range ± 75% of full scale
Jitter:	
Phase jitter scan-to-scan:	80 ps rms
Phase jitter card-to-card:	41 ns peak 12 ns rms

Measurement Accuracy

Typically ± 0.01% of input level; varies with the SCP used. Specifications are 90 days, 23 ± 1° C, with *CAL done after a 1 hr warm-up and CAL:ZERO done within 5 minutes.

Note: Beyond the 5 min. limitation and CAL:ZERO not done, apply the following drift error: Drift = 10µV/° C ÷ SCP gain, per ° C change from CAL:ZERO temperature.

Accuracy Data

Measurement accuracy is dependent upon the SCP module used. Refer to the accuracy tables and graphs for the individual SCP to determine the overall measurement accuracy.

Many definitions of accuracy are possible. Here we use single-shot with 3 sigma noise. To calculate accuracy assuming temperature is held constant within ± 1° C of the temperature at calibration, the following formula applies:

$$\text{Single Shot } 3\sigma = \pm(\sqrt{(\text{GainError})^2 + (\text{OffsetError})^2} + 3\sigma \text{ noise})$$

Correcting for Temperature

To calculate accuracy over temperature range outside the ± 1 °C range, results after *CAL are given by replacing each of the above error terms as follows:

Replace

$$(\text{GainError})^2$$

with

$$(\text{GainError})^2 + (\text{GainTempco})^2$$

Replace

$$(\text{OffsetError})^2$$

with

$$(\text{OffsetError})^2 + (\text{OffsetTempco})^2$$

Loop Control Specifications

Number of loops: 1 to 32

Default control algorithm type: PID

Maximum E1415A loop update rate for default PID algorithm:

(Note: E1422A maximum sample rate is 25 kSamples/s, compared to 56 kSamples/s for the E1415A. The loop speeds of the E1422A are reduced in same ratio.)

1 loop:	3 kHz
8 loops:	1 kHz
32 loops:	250 Hz

Custom algorithm development:

Language:	Subset of C, programming language including if-then-else, most math and comparison operations.
Variable types:	Scalar local and global variables, array local and global variables.
Intrinsic functions:	interrupt(), writefifo(), writecvt(), writeboth(), min(), max(), abs().
Other functions:	Create own custom functions to handle transcendental operations.

I/O General

A total of eight (8) Signal Conditioning Plug-ons (SCPs) can be installed in most combinations of input or output configurations on a single E1415A/E1422A.

Power Available for SCPs

±24 V:	1.0 A
5 V:	3.5 A

General Specifications

VXI Characteristics

VXI device type:	A16, slave only, register based
Data transfer bus:	n/a
Size:	C
Slots:	1
Connectors:	P1/2
Shared memory:	n/a
VXI buses:	TTL Trigger bus (T)

Instrument Drivers - See the Agilent Technologies Website (http://www.agilent.com/find/inst_drivers) for driver availability and downloading.

Command module firmware:	Downloadable
Command module firmware rev:	A.08
I-SCPI Win 3.1:	No
I-SCPI Series 700:	Yes
C-SCPI LynxOS:	Yes
C-SCPI Series 700:	Yes
Panel Drivers:	No
VXIplug&play Win Framework:	No
VXIplug&play Win 95/98/NT Framework:	Yes
VXIplug&play HP-UX Framework:	No

*The Agilent VEE Application can use VXIplug&play drivers or panel drivers.

Module Current

	I_{PM} (A)	I_{DM} (A)
+5 V:	1.0	0.02
+12 V:	0.06	0.01
-12 V:	—	—
+24 V:	0.01	0.01
-24 V:	0.1	0.01
-5.2 V:	0.15	0.01
-2 V:	—	—

Cooling/Slot

Watts/slot:	14.00
ΔP mm H₂O:	0.08
Air flow liter/s:	0.8

Ordering Information

Description	Product No.
Algorithmic Closed Loop Controller	E1415A
Interface to rack mount terminal panel	E1415A A3F
3 yr. retrn. to Agilent to 1 yr. OnSite warr.	E1415A W01
Remote Channel Multi-function Data Acquisition & Control Module	E1422A
16-Port RJ-45 Connector Block	E1422A 001
Screw Terminal Connector Block	E1422A 011
Spring Clamp Terminal Connector	E1422A 013
8-Channel Direct Input SCP	E1501A
8-Channel 7 Hz Low-pass Filter SCP	E1502A
8-Channel Programmable Filter/Gain SCP	E1503A
8-Channel Current Source SCP	E1505A
8-Channel 120 Ω Strain Completion & Excitation SCP	E1506A
8-Channel 350 Ω Strain Completion & Excitation SCP	E1507A
8-Channel x16 Gain & 7 Hz Fixed Filter SCP	E1508A
8-Channel x64 Gain & 7 Hz Fixed Filter SCP	E1509A
4-Channel Sample & Hold Input SCP	E1510A
4-Channel Transient Strain SCP	E1511A
8-Channel 25 Hz Fixed Filter SCP	E1512A
8-Channel \div 16 Fixed Attenuator & 7 Hz Low-pass Filter SCP	E1513A
4-Wire Resistance Measurement SCP	E1518A
8-Channel Voltage Output SCP	E1531A
8-Channel Current Output SCP	E1532A
16-Bit Digital I/O SCP	E1533A
8-Bit Isolated Digital I/O SCP	E1536A
Enhanced Frequency/Totalize/PWM SCP	E1538A
Remote Channel Signal Conditioning Plug-on	E1539A

For More Information

For more information on individual SCPs, refer to the corresponding catalog pages for those products, or contact Agilent to request individual data sheets. For more information on the E1422A/E1529A/E1539A Strain Measurement System, refer to *Agilent E1529A, E1539A, and E1422A Strain Measurement Product Overview*, Pub No. 5968-0432E.

Agilent Technologies' Test and Measurement Support, Services, and Assistance

Agilent Technologies aims to maximize the value you receive, while minimizing your risk and problems. We strive to ensure that you get the test and measurement capabilities you paid for and obtain the support you need. Our extensive support resources and services can help you choose the right Agilent products for your applications and apply them successfully. Every instrument and system we sell has a global warranty. Support is available for at least five years beyond the production life of the product. Two concepts underlie Agilent's overall support policy: "Our Promise" and "Your Advantage."

Our Promise

Our Promise means your Agilent test and measurement equipment will meet its advertised performance and functionality. When you are choosing new equipment, we will help you with product information, including realistic performance specifications and practical recommendations from experienced test engineers. When you use Agilent equipment, we can verify that it works properly, help with product operation, and provide basic measurement assistance for the use of specified capabilities, at no extra cost upon request. Many self-help tools are available.

Your Advantage

Your Advantage means that Agilent offers a wide range of additional expert test and measurement services, which you can purchase according to your unique technical and business needs. Solve problems efficiently and gain a competitive edge by contracting with us for calibration, extra-cost upgrades, out-of-warranty repairs, and on-site education and training, as well as design, system integration, project management, and other professional engineering services. Experienced Agilent engineers and technicians worldwide can help you maximize your productivity, optimize the return on investment of your Agilent instruments and systems, and obtain dependable measurement accuracy for the life of those products.

By internet, phone, or fax, get assistance with all your test & measurement needs.

Online assistance:

www.agilent.com/find/assist

Phone or Fax

United States:
(tel) 1 800 452 4844

Canada:
(tel) 1 877 894 4414
(fax) (905) 282 6495

China:
(tel) 800 810 0189
(fax) 1 0800 650 0121

Europe:
(tel) (31 20) 547 2323
(fax) (31 20) 547 2390

Japan:
(tel) (81) 426 56 7832
(fax) (81) 426 56 7840

Korea:
(tel) (82 2) 2004 5004
(fax) (82 2) 2004 5115

Latin America:
(tel) (305) 269 7500
(fax) (305) 269 7599

Taiwan:
(tel) 080 004 7866
(fax) (886 2) 2545 6723

Other Asia Pacific Countries:
(tel) (65) 375 8100
(fax) (65) 836 0252
Email: tm_asia@agilent.com

Product specifications and descriptions in this document subject to change without notice.

© Agilent Technologies, Inc. 2001
Printed in USA September 1, 2001
5965-5585E



Agilent Technologies